



VP-LIFT

VACUUM ELEVATORS

TECHNICAL INFORMATION

MODEL	UB 30	UB 37	UB 52
Power supply:	220 VAC - 60 Hz		
Motor Power:	2,7Kw	4,5Kw	
External cylinder diameter:	75cm	95cm	134 cm
Internal Cabin diameter :	64cm	82cm	112cm
Internal cabin height:	200cm	195cm	200cm
Ceiling perforation:	81cm	99 cm	137cm
Total Weight:	2-stops: 254 kg	2-stops: 363 kg	2-stops: 680kg / 3-stops: 925kg
Lift Capacity, for the standard model:	100 kg	205 kg	238 kg
Velocity:	15cm/sec	15cm/sec	10cm/sec
Illumination:	Halogen lights		
Electrical circuits:	24-volt		
Lubrication:	Not required		
Installation:	No excavation or shaft required. Elevator rests on floor, self supported.		
Safety:	Pressure switch: on free fall elevator brakes within 5cm Rescue system: On electricity cut, elevator automatically descends to ground floor.telephone(optional) Alarm system in cabin , emergency ventilation, door safety switches		
Warranty:	One year on parts and labor		

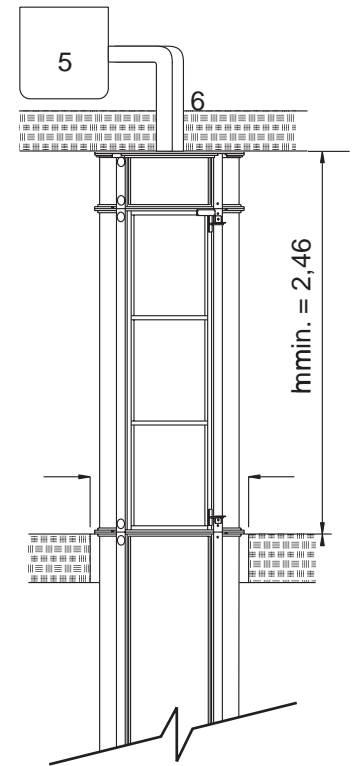
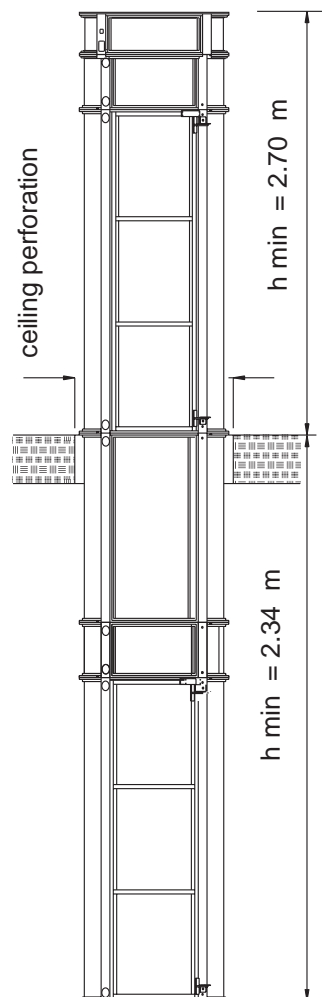
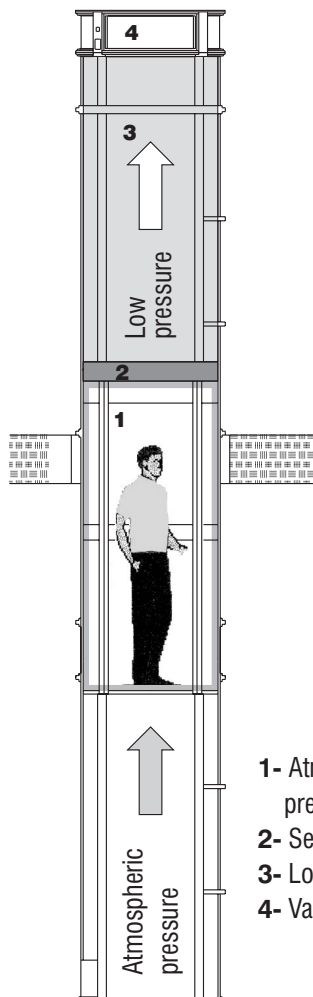

SPLIT model

- 5 - Vacuum pump's box
29" x 18" x 21"
- 6 - PVC's pipes $\varnothing 4\frac{1}{2}$ "